

# Installation Instructions

## SOFT CLOSE PEGASUS DRESSING TABLE

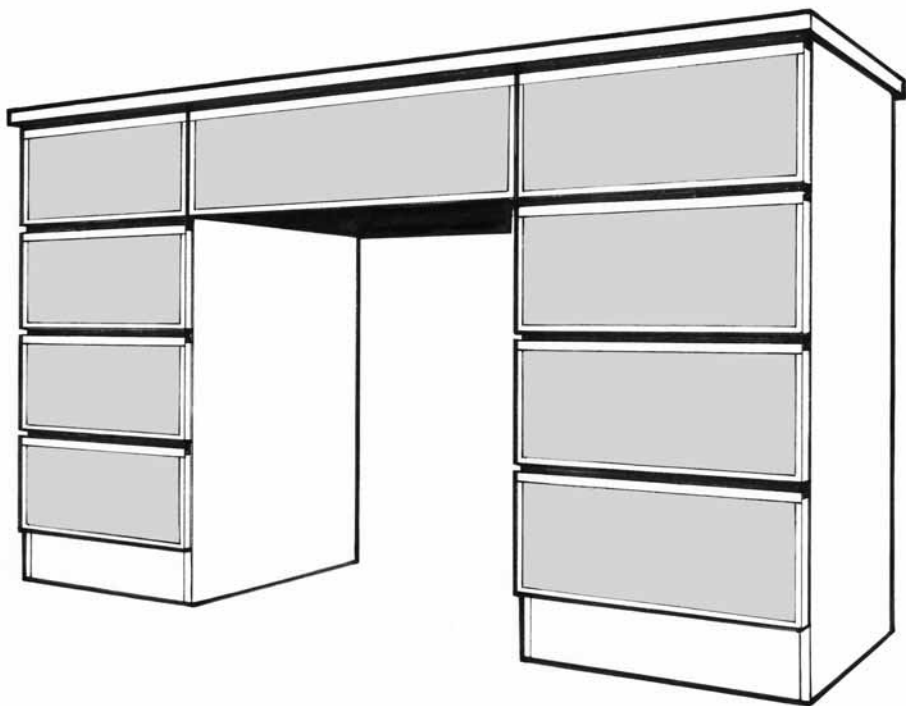

## PREPARATION

Ensure that the area for assembly is flat, clean and free from any particals which can scratch the surfaces.

Study the instructions for order of assembly and familiarise yourself with all the parts and the dowels are placed in the correct holes and panels.

It is very important to ensure the arrow on the cam aligns with the hole in the side section (see diagram).

Take care not to bend or twist the panels as this will weaken the clamp joints.

**PLEASE NOTE:** The large cams are for the main carcass, the small cams are for the drawer wraps.

Check that the arrow on the cam aligns with the clamp (see diagram).

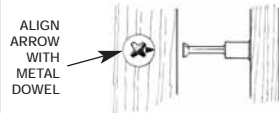

2 SIZES  
CAMS 15mm FOR THE DRAWER  
CAMS 18mm FOR THE CARCASS



METAL DOWEL



DOWEL



EURO SCREW

# 1

## ASSEMBLING THE DRAWERS SIDE CARCASSES

Position the two drawer side panels as diagram.

Following the diagram, insert the wood and metal dowels.

Position drawer rails, 5mm from front face, fix with Euro screws provided into the two holes exposed through the rails.

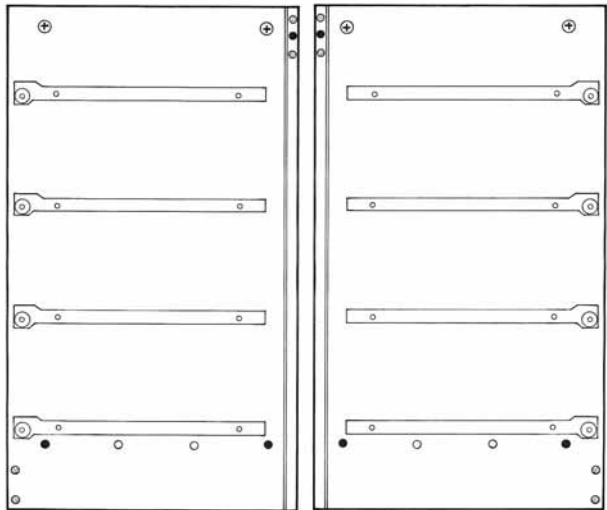

 DOWELS

 METAL DOWELS

# 2

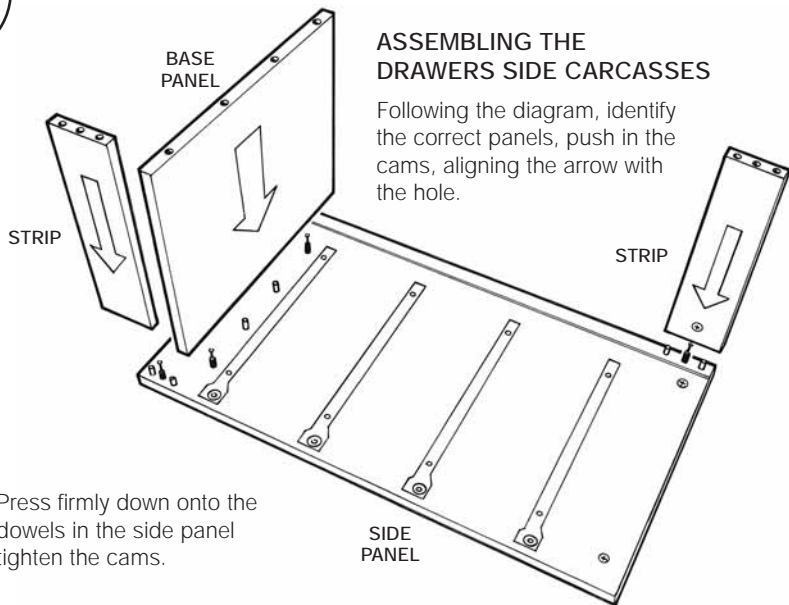

# 3

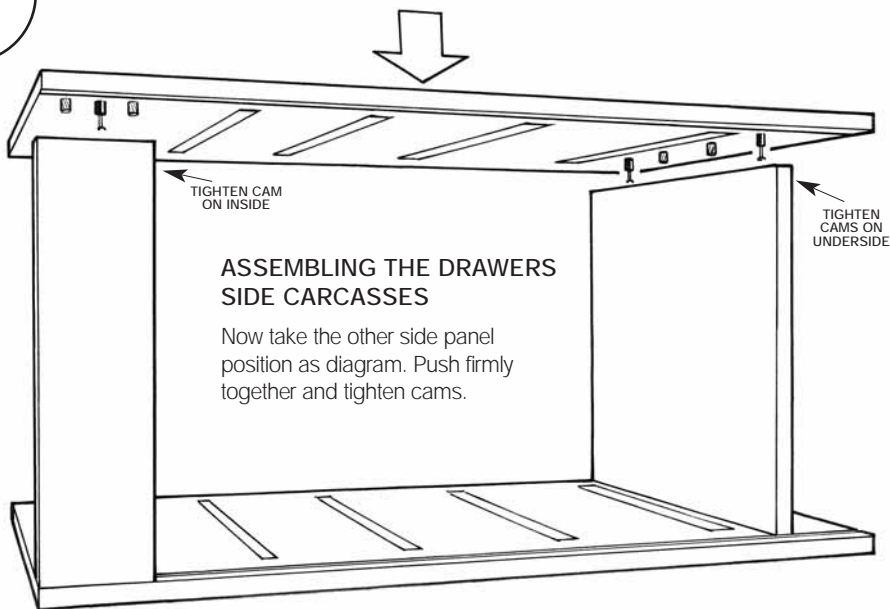

4

### SLIDING IN THE BACK PANEL

Slide in the panel to the bottom edge of the base panel.

5mm should be left at the top of the unit for the panel to fit into groove on the top panel (see diagram).

Drill three holes and fix back panel using 3.5mm dia x 16mm long csk wood screws provided.

This side drawer carcass is now complete, repeat this process for the other side drawer unit.

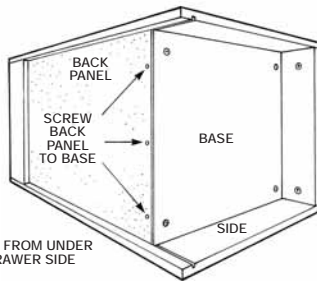
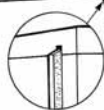
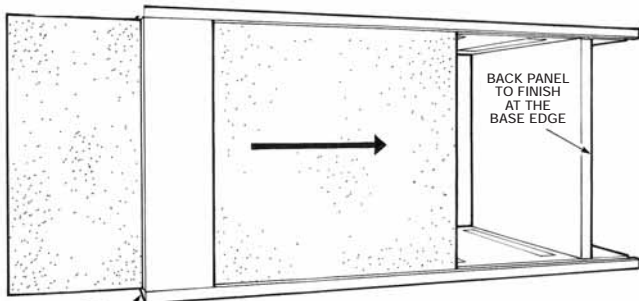

5

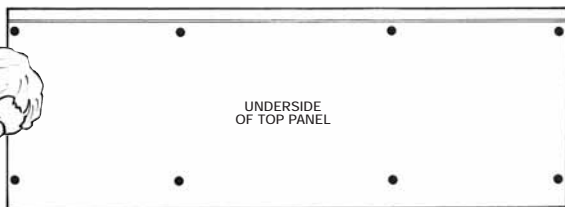
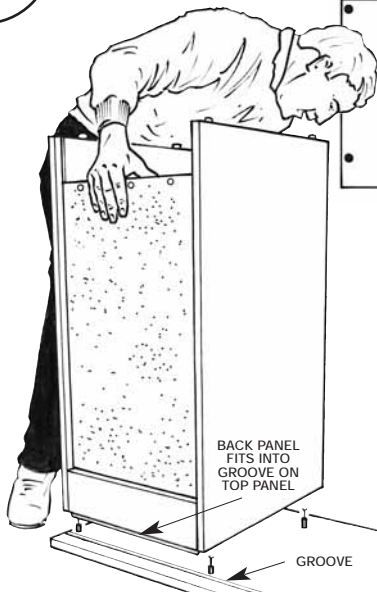

### FITTING DRAWERS CARCASS TO THE TOP

Lay top panel face down taking care not to scratch the surface.

Place in eight metal dowels into the holes (see diagram).

Position drawer side onto the dowels taking care not to bend or damage holes.

When firmly down, tighten cams from the inside.

Repeat on the other end.

# 6

○ DOWELS      ● METAL DOWELS

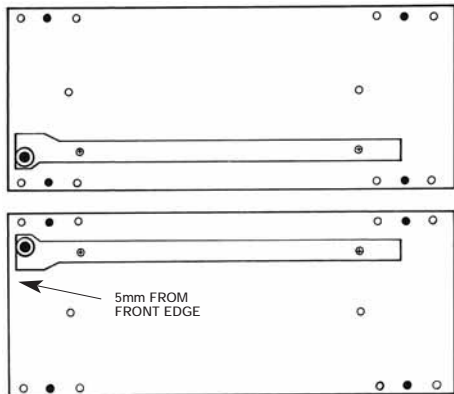

## ASSEMBLING THE LINK DRAWER CARCASS

Take the four bar panels and insert the cams into each end making sure arrow aligns with holes in the ends.

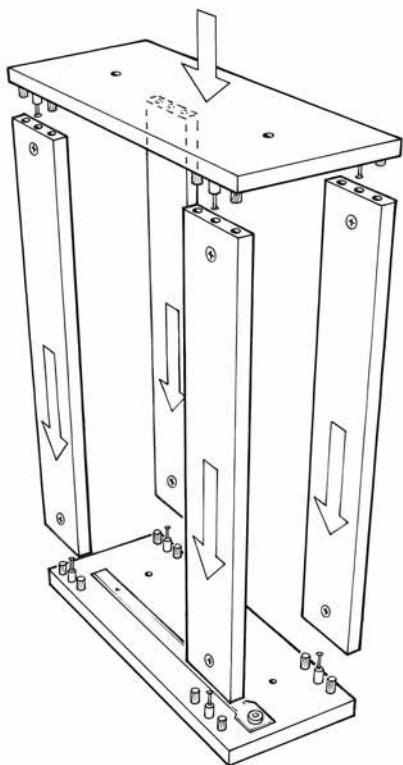
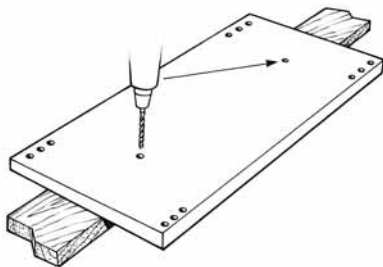

Drill through the two holes as diagram, taking care not to split the surface on the front face. This is to secure the link drawer to the side drawers later in the build.

Position strips as diagram, cams facing underneath, note the drawers rail position. Now tighten 8 cams. The link drawers carcass is now complete.

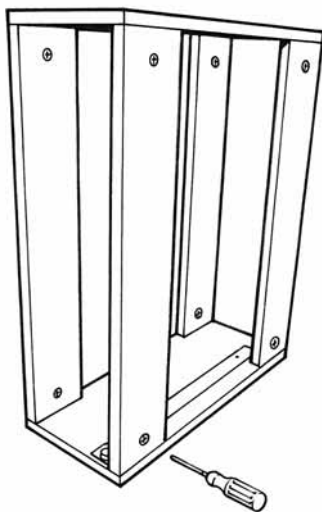

7

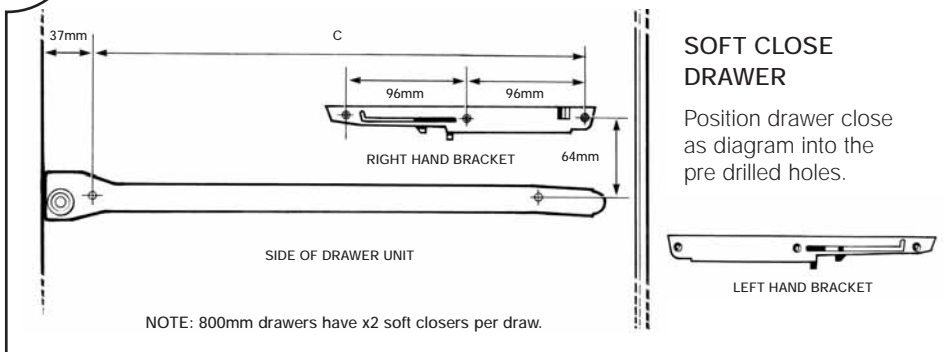

8

### FITTING THE LINK DRAWER CARCASS

Slide in the link drawer carcass between the two drawers sides.

The wheel on the drawer runners should be same as the side units, facing the front.

Make sure the front edge aligns (see diagram).

Drill through the four holes (two each side) just enough to break through the hard surface of the drawer sides.

Secure using 4.0mm dia x 30mm long csk wood screws provided.

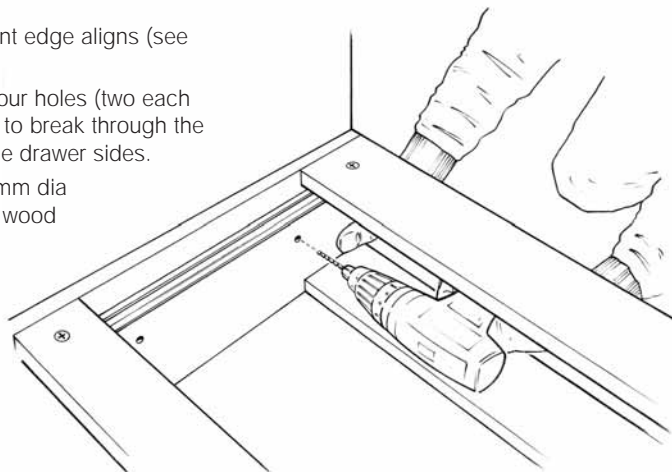

## ASSEMBLING THE DRAWERS

All the drawers are constructed in the same way, familiarise yourself with the parts.

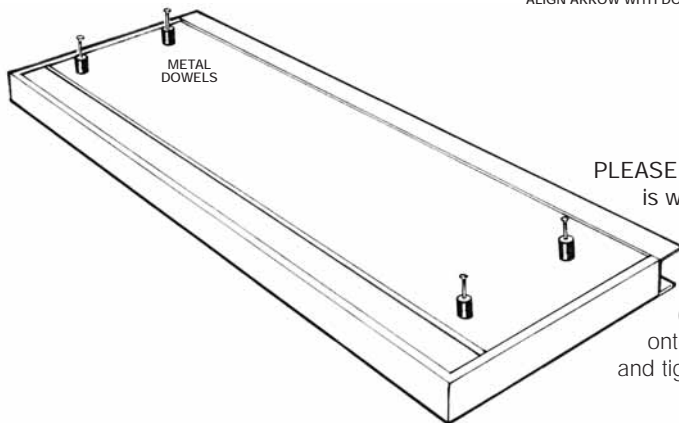
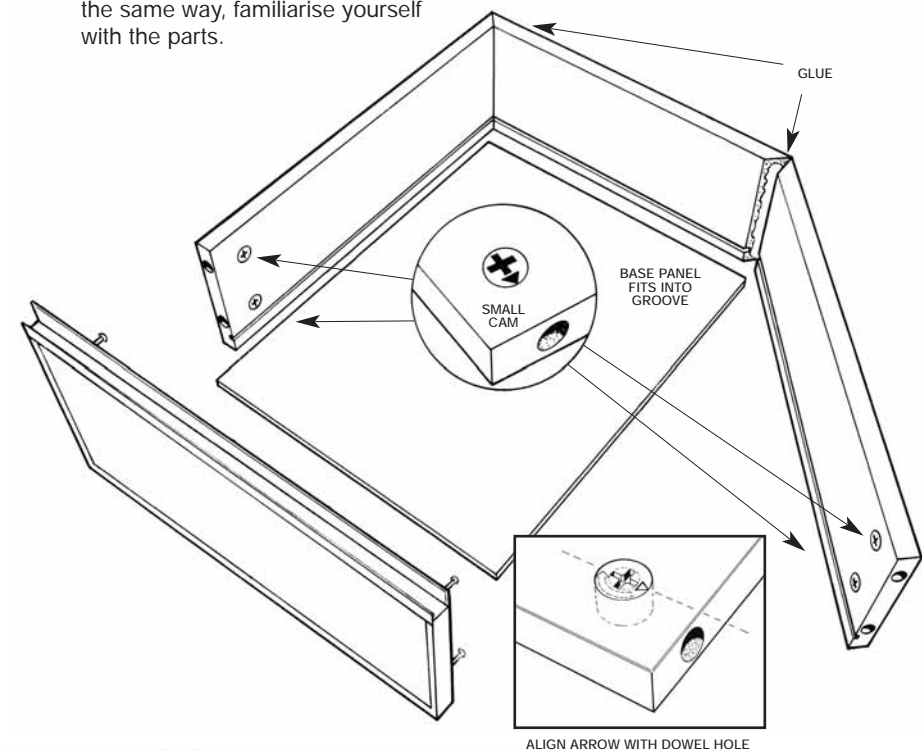

**PLEASE NOTE:** Link drawer is wider than the side drawers.

Insert metal dowels into the drawer front (as diagram). Push onto drawer sides and tighten cams.

# 10

## FITTING THE DRAWER RUNNERS

Place runners onto the base of the drawers (see diagram).

Fix the small screws provided you may need to pierce the hard surface to allow the screw to go in easily.

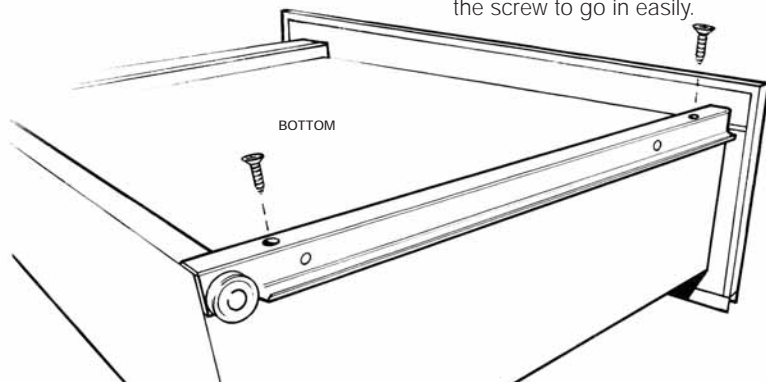

# 11

## FITTING SOFT CLOSE DRAWER CATCHERS

Position as diagram, adjust as necessary.

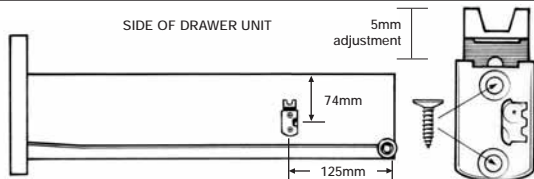

**DO NOT USE ABRASIVE OR CHEMICAL BASED CLEANING AGENTS OR FILLERS ON THE FRAMES OF YOUR SPACESLIDE PRODUCTS; IT MAY RESULT IN TARNISHING OR PEELING.**



Pushing back the boundaries of space

Spaceslide Showrooms

Northgate, **Aldridge**, Walsall, West Midlands WS9 8TH

T: 01922 743211 - F: 01922 743513 - E: sales@spaceslide.co.uk

Drew House, Ebbens Road, Apsley, **Hemel Hempstead**, Hertfordshire HP3 9QS

Retail: 01442 239900 - Trade: 01442 269963 / 252299 - F: 01442 244121 E: sales@spaceslide.co.uk

[www.spaceslide.co.uk](http://www.spaceslide.co.uk)