

Installation Instructions

SOFT CLOSE PEGASUS 3, 4 & 6 DRAWER UNITS

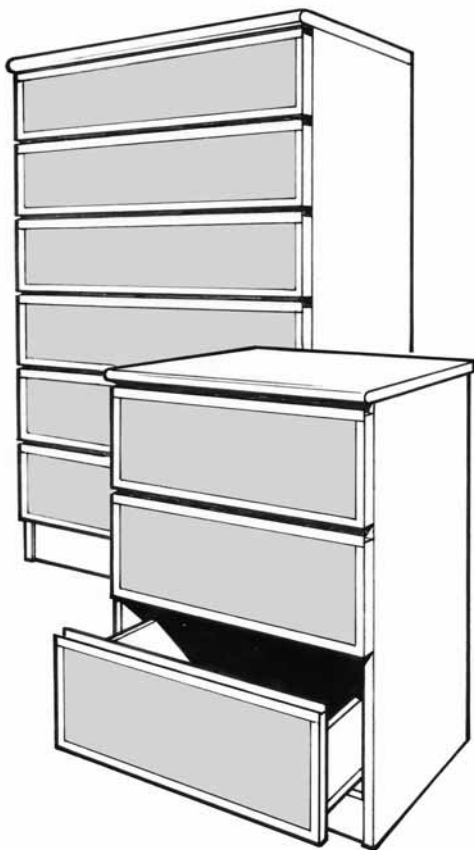

Only open one drawer at a time. Never leave drawers open as unit will be top heavy and may fall forward.

PREPARATION

Ensure that the area for assembly is flat, clean and free from any particles which can scratch the surfaces.

Study the instructions for order of assembly and familiarise yourself with all the parts.

The unit is supplied with dowels, cams and a sachet of glue for the drawer corners.

Follow the diagram to ensure dowels and cams are in the correct holes.

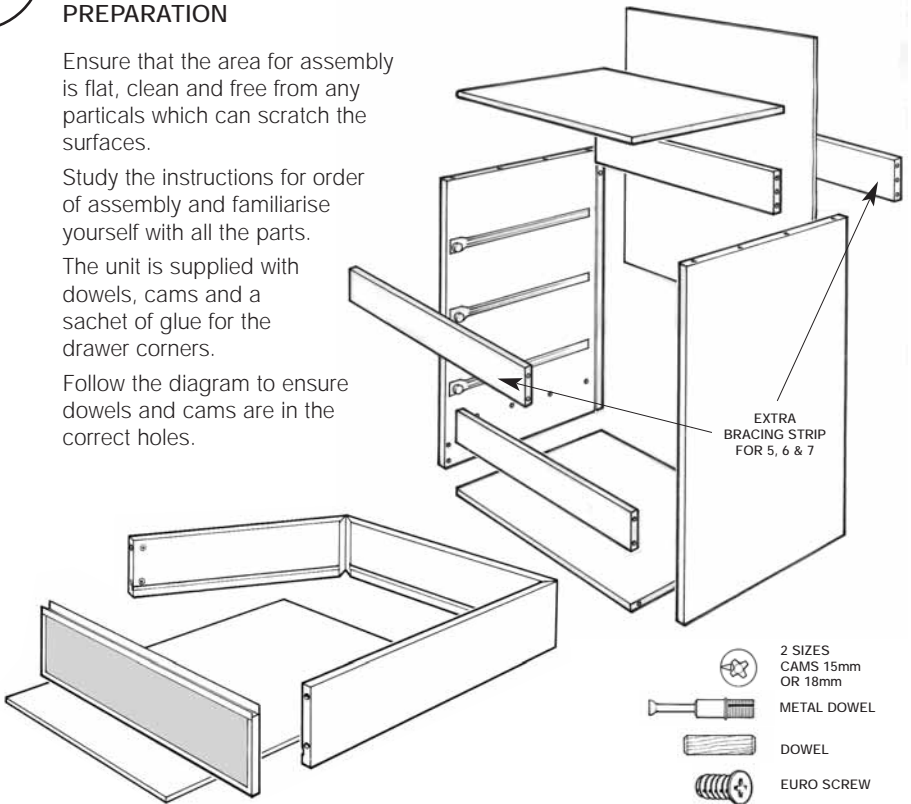

Check that the arrow on the cam aligns with the metal dowel (see diagram).

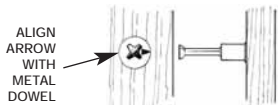

Take care not to bend or twist the panels as this will weaken the cams.

REAR

FRONT

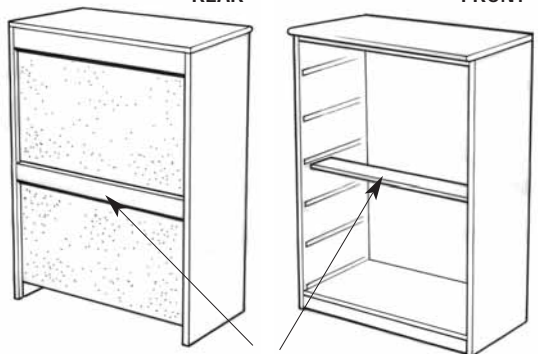

BRACING STRIPS
(FOR 6 DRAWER UNIT ONLY)

1

ASSEMBLING THE DRAWERS

Lay to drawer sides and back onto a flat surface.

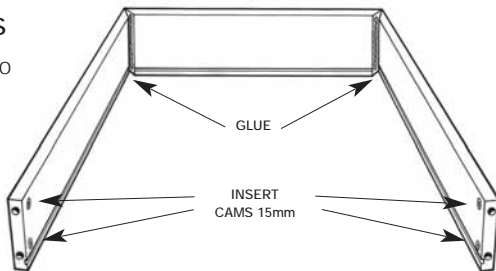
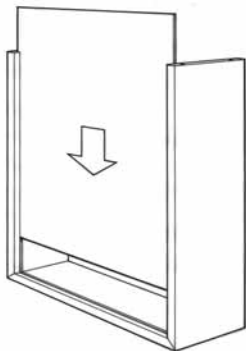

With the glue sachet provided, place a small quantity of glue onto the mitred surface which make up the draw corners.

Fold the draw sides and insert the base panel down the grooves (see diagram).

Wipe off any excess glue from the draw corners.

2

FITTING THE FRONT FACE

Fit dowels in back of drawer fronts.

Insert four cams into the drawer side, check arrow alignment and press the front panel onto the draw sides.

Tighten the four cams inside the drawer to complete the assembly.

Repeat the process on all the other drawers.

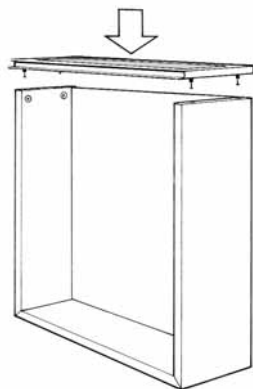
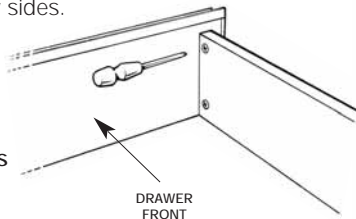

3

FITTING THE DRAWER RUNNERS

Position the drawer runners with the wheels at the back (see diagram). With a bradle make three small pilot holes into the base through the round holes and fix with 12mm x 3.5mm screws provided.

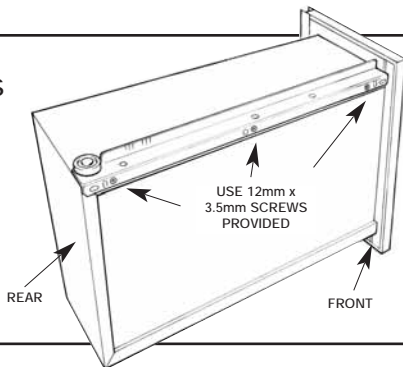

4

FITTING SOFT CLOSE DRAWER CATCHERS

Position as diagram, adjust as necessary.

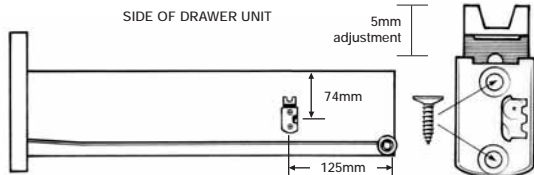

5

PREPARING THE OUTER FRAME

Lay both sides together on a flat surface as diagram. Position the drawer runners and secure using 10mm x 6mm screws provided

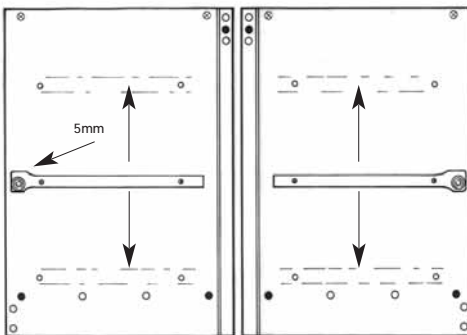

through the holes indicated on the runner diagram.

Insert the cams and dowels into the correct holes indicated in the diagram.

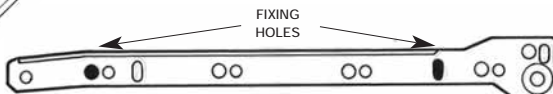
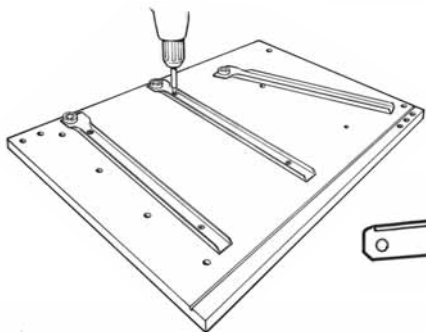

RUNNER DIAGRAM

SOFT CLOSE DRAWER

Position drawer close as diagram into the pre drilled holes.

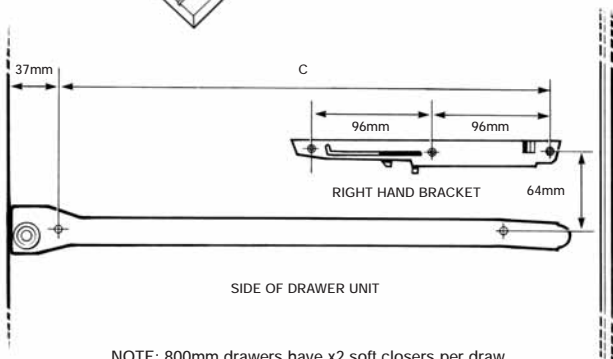

NOTE: 800mm drawers have x2 soft closers per draw.

6

ASSEMBLING THE OUTER FRAME

Check the arrow alignment on the cams.
Using one side panel carefully position the bottom panel onto the cams and dowels. Press together and tighten the cams.

Identify the rear and front bracing strips. Insert 2 dowels in each end and one cam in the middle hole in the top bracing (see diagram).

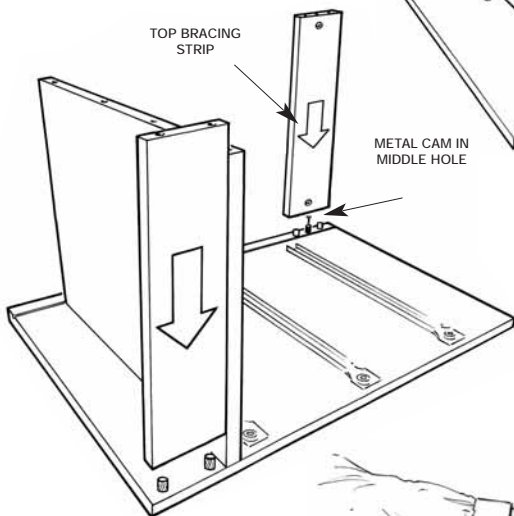

NOTE: On the 6 drawer units two extra bracing strips are supplied. Fit as previous with cams and dowels (see diagram on preparation section for position).

Carefully position the other side panel onto the cams and dowels, tap together with the flat of your hand (see diagram).

Tighten the four cams as previous side panel.

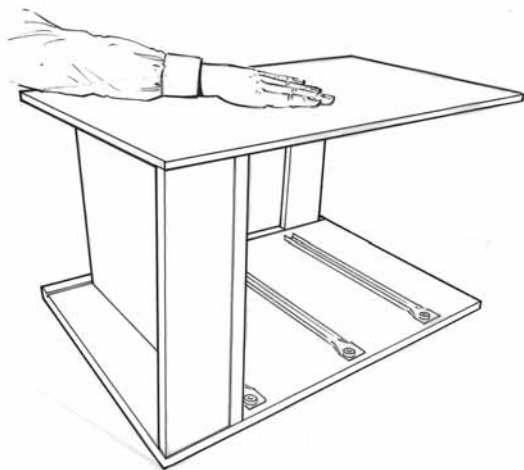

FITTING THE TOP PANEL

Very carefully lift the drawer unit into it's upright position.

Insert the cams and dowels in the top panel (metal cams on the four corners).

Locate holes carefully and press down.

Tighten cams on the inside (see diagram).

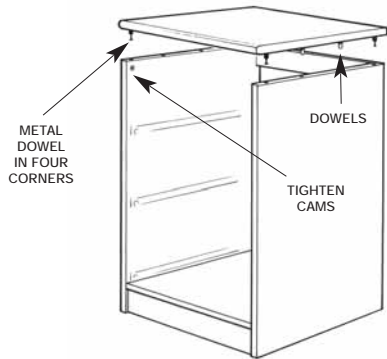

FITTING THE BACK PANEL

Turn the draw unit onto it's top then slide down the back panel in the groove fully down to rest on the top panel.

To stop the panel sliding out, drill a small pilot hole through the back panel into the bracing strip. Just enough to break through the hard melamine surface (see diagram).

Fix with two screws provided.

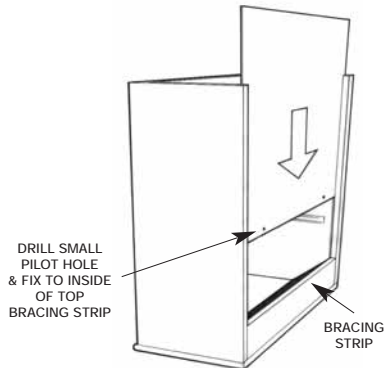

DO NOT USE ABRASIVE OR CHEMICAL BASED CLEANING AGENTS OR FILLERS ON THE FRAMES OF YOUR SPACESLIDE PRODUCTS; IT MAY RESULT IN TARNISHING OR PEELING.



Pushing back the boundaries of space

Spaceslide Showrooms

Northgate, **Aldridge**, Walsall, West Midlands WS9 8TH

T: 01922 743211 - F: 01922 743513 - E: sales@spaceslide.co.uk

Drew House, Ebbens Road, Apsley, **Hemel Hempstead**, Hertfordshire HP3 9QS

Retail: 01442 239900 - Trade: 01442 269963 / 252299 - F: 01442 244121 E: sales@spaceslide.co.uk

www.spaceslide.co.uk